

# The Adaptation and Acceptance of Defocus Incorporated Multiple Segment Lens for Chinese Children



YIQIU LU, ZHENGHUA LIN, LONGBO WEN, WENYU GAO, LUN PAN, XIAONING LI, ZHIKUAN YANG, AND WEIZHONG LAN

- **PURPOSE:** We investigated the adaptability and acceptance of a novel spectacle lens design that was recently reported to achieve a significant antimyopia effect.
- **DESIGN:** A prospective, cross-over study.
- **METHODS:** Twenty children were recruited to wear both Defocus Incorporated Multiple Segments (DIMS) and single vision (SV) lens, with a random assignment of which type of lens was experienced first. For each type of lens, high and low contrast central distant visual acuity (VA) and high contrast mid-peripheral near VA were measured at both 500 lux and 50 lux ambient illumination after 30 minutes' and a week's wearing of the lens. A self-developed questionnaire was applied to evaluate the visual discomfort at the 1-week visit. All quantitative data were analyzed by paired *t* test, while qualitative data were analyzed with the  $\chi^2$  or Wilcoxon signed-rank tests.
- **RESULTS:** Central VA was not affected by DIMS lens compared with SV lens in all circumstances (all  $P > .05$ ). However, the mid-peripheral near VA was found to reduce by approximately 0.06 logarithm of minimal angle of resolution unit in 2 of 4 quadrants (500 lux;  $P < .05$ ) and in 3 quadrants (50 lux;  $P < .05$ ) for DIMS lenses. No improvement was detected in the 1-week visit. Mid-peripheral blurred vision was the main visual complaint, which was noticed only once or twice a day. Being aware of the average antimyopic efficacy, 90% of children subjects preferred DIMS lenses.
- **CONCLUSION:** Mid-peripheral vision through DIMS lenses was slightly affected compared with SV lenses. Otherwise, DIMS lenses received good tolerance and acceptance by Chinese children. (Am J Ophthalmol 2020;211: 207–216. © 2019 The Authors. Published by Elsevier Inc. This is an open access article under the CC BY-NC-ND license (<http://creativecommons.org/licenses/by-nc-nd/4.0/>).

AJO.com

Supplemental Material available at [AJO.com](http://AJO.com).

Accepted for publication Dec 5, 2019.

From the Aier School of Ophthalmology (Y.L., Z.L., L.W., W.G., L.P., X.L., Z.Y., W.L.), Central South University, Changsha; Aier School of Optometry (X.L., Z.Y., W.L.), Hubei University of Science and Technology, Xianning; and the Aier Institute of Optometry and Vision Science (W.G., L.P., X.L., Z.Y., W.L.), Aier Eye Hospital Group, Changsha, China.

Inquiries to Weizhong Lan, Aier School of Ophthalmology, Central South University, 18th Floor, New Century Building, No. 198, Furong Middle Road, Changsha, 410015, China; e-mail: [lanweizhong@aierchina.com](mailto:lanweizhong@aierchina.com)

AS ONE OF THE MAIN CAUSES OF BLINDNESS, MYOPIA has become a global public health problem. It is estimated that approximately 2 billion people in the globe currently suffer from myopia, and that number is predicted to increase to nearly 50% of the world's population by 2050.<sup>1</sup> From a global perspective, the prevalence of myopia is especially high in East and Southeast Asia—for instance, in China.<sup>2</sup> Myopia, if left untreated, will progress into high myopia (ie,  $>6$  diopters [D]) and will significantly increase the risk of developing cases of irreversible visual impairment, such as glaucoma,<sup>3,4</sup> retinal degeneration, and retinal detachment.<sup>2,5,6</sup> Therefore, it is urgent to find a safe, effective approach to slow down myopia progression to reduce the incidence of these complications. Progressive myopia also primarily occurs in children, and because treatment usually needs to last for many years, an ideal approach should also be convenient and easily tolerated to ensure compliance.

It is well documented that ocular growth is principally visually guided.<sup>7,8</sup> For instance, when the image plane is artificially shifted behind the retina by a negative lens (ie, hyperopic defocus), ocular growth is stimulated and relative myopia develops. By contrast, when the image plane is shifted in front of the retina by a positive lens (ie, myopic defocus), ocular growth is inhibited and relative hyperopia develops.<sup>9–15</sup> Based on this principle, many optical approaches aiming to slow myopic progression have been introduced in recent years.<sup>16–18</sup> Lam and associates<sup>19</sup> recently introduced a novel lens design: the Defocus Incorporated Multiple Segment (DIMS) lens. Unlike previous lens designs, the myopic defocus area in the peripheral portion of the DIMS lens is a new honeycomb multizone design that includes a +3.50 D myopic defocus zone and a clear zone with central power (Figure 1). In the results of these researchers' randomized controlled clinical trial, the DIMS lens slowed myopia progression by 59% and inhibited axial growth by 60% compared with the traditional single vision (SV) lens; this was one of the top rankings of efficacy in the published literature.<sup>16–18,20–26</sup> Given its nature as a spectacle lens, the DIMS lens seems to be a more ideal solution for myopia control compared with contact lenses and drugs with regard to safety, tolerance, and convenience. To provide more guidance with these lenses with respect to clinical dispensing in practice, the

current study was conducted to investigate the adaptability and acceptability of the DIMS lens in Chinese youth.

## METHODS

THIS IS A PROSPECTIVE CROSSOVER STUDY. ALL PROCEDURES of the study met the tenets of the Declaration of Helsinki and were approved by the Human Subjects Ethics Committee of the Aier Eye School of Ophthalmology, Central South University (AIER2018IRB07). Written assent and informed consent were obtained from the children and their parents or from the adult volunteers themselves before participation.

- **SUBJECTS:** As the users of DIMS lenses are children with myopia control as the main appeal, children with myopia were the main subjects in the study. Some children might not be able to express their feeling about the lenses precisely because of age-related inarticulateness, and therefore another group of adult volunteers were also set intentionally. In order to obtain the strictest appraisal of the tested lenses, adult volunteers were invited from the residential ophthalmologists at Central South University. The inclusion criteria were as follows: 1) children group: 7–15 years of age; adult group: 18–30 years of age; 2) spherical equivalent refraction (SER) (ie, spherical power plus 1/2 cylindrical power):  $-0.50$  to  $-6.00$  D; 3) astigmatism of  $\leq 1.50$  D; 4) interocular anisometropia of  $\leq 1.25$  D; 5) best-corrected visual acuity (VA): 0.2 logarithm of minimal angle of resolution or better; 6) free of ocular and systemic abnormalities that might affect visual functions or refractive development; and 7) willingness to wear spectacle lenses constantly during waking hours.

After having a comprehensive examination as mentioned above, 20 children (13 females and 7 males  $10.80 \pm 2.55$  years of age; SER  $-3.03 \pm 1.73$  D) and 10 adults (7 women and 3 men  $25.60 \pm 2.01$  years of age; SER  $-3.38 \pm 1.44$  D) were recruited for the study.

- **LENSES:** The material of the DIMS lens was polycarbonate with a refractive index of 1.590 and a spherical design, except for the mid-peripheral defocus area. A diagram of the optical design of a DIMS lens is shown in Figure 1. The SV lens was of a resin material with a refractive index of 1.669 and a spherical design. Both DIMS and SV lenses were provided by Hoya Co., Ltd. (Tokyo, Japan).

- **STUDY DESIGN:** *Determination of refractive error.* After a comprehensive ocular health examination, cycloplegia was achieved in the children by instilling 1 drop of compound tropicamide in both eyes (0.5% tropicamide plus 0.5% phenylephrine hydrochloride [Santen Pharmaceutical Co., Osaka, Japan]) 3 times at 5-minute intervals. Direct light reflex was detected 30 minutes after the last

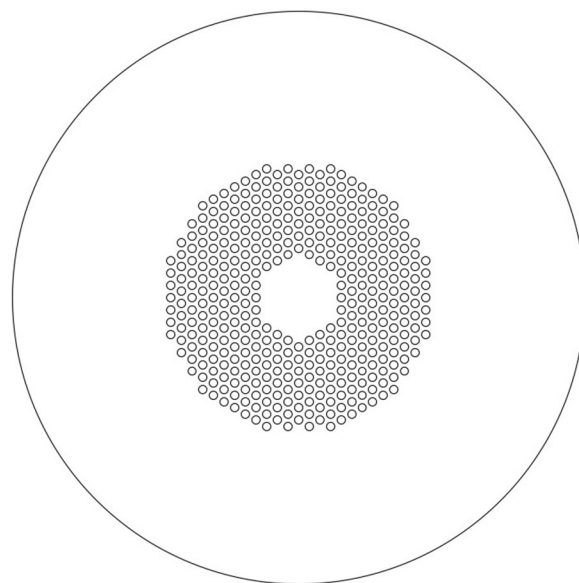

**FIGURE 1.** The optical design of Defocus Incorporated Multiple Segments (DIMS) lenses. The center of DIMS (diameter 9.40 mm) is a clear vision zone with the central refractive power of the wearer. The mid-peripheral zone (diameter of 33 mm) is a honeycomb design area in which the area ratio between +3.50 diopters myopic defocus (unfilled circles) and the clear vision area with the central refractive power (area between the unfilled circles) is approximately 50:50.

administration of the eyedrop. Retinoscopy was performed after the absence of the pupil light reflex was achieved. Subjective refraction with maximum plus to maximum VA as an endpoint was then conducted the following day to determine the refractive prescription for the children. By contrast, only subjective refraction without cycloplegia was conducted to determine the refractive prescription for the adult volunteers. After that, investigators helped the volunteers select and adjust the spectacle frames. Special attention was paid to ensure that the pupil distance and pupil heights for both eyes were measured properly. Subsequently, members of both groups were requested to wear both types of lenses with a random assignment of which type of lenses was experienced first and were requested to perform the following examinations. During these procedures, neither the subjects nor the examiners were informed the type of the lenses the subject was wearing.

VA. After subjects wore the assigned lenses for 30 minutes, the distant VA in the primary gaze was examined under both standard (500 lux) and dim (50 lux) illuminance, using high- (100%) and low-contrast (10%) Early Treatment Diabetic Retinopathy Study visual charts. Near VA at 40 cm through the mid-peripheral zone was also measured under these 2 levels of ambient illuminance. To make sure the subject looked through

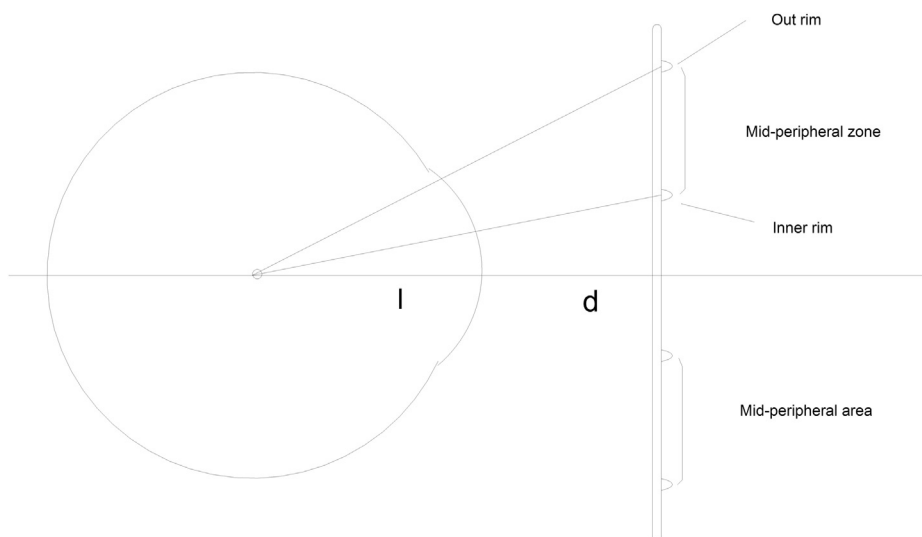

FIGURE 2. Illustration of the rotation angle of the eyeball related to the rims of the mid-peripheral zone of the Defocus Incorporated Multiple Segments (DIMS) lens. Assuming the rotation center of the eyeball is 14.5 mm behind the apex of the cornea<sup>27</sup> and the vertex distance is 15 mm, then the line of central sight through the mid-peripheral zone was approximately 8°-28°.

the mid-peripheral zone, the near visual chart was placed in the superior, inferior, nasal, or temporal direction 20° away from the horizontal visual axis (Figure 2) while the subject's head was fixed by a chin rest. The same procedure was repeated after wearing either lens for a week. VA in the report was expressed in logarithm of minimal angle of resolution units.

*Visual complaints.* Participants were requested to complete the visual performance questionnaire at the 1-week visit of each type of lenses, in which they were requested to select listed symptoms and give a score according to the frequency of noticeable occurrence: 0 = none (0 times/day), 1 = occasionally (1-2 times/day), 2 = sometimes (3-4 times/day), 3 = always (5-6 times/day), 4 = complete (>7 times/day) (Appendix I; available online at [AJO.com](http://AJO.com)). After 2 types of lenses were tried, the acceptability of these lenses was evaluated by answering another questionnaire with the following questions: 1) Would you like to wear the first type of lenses in your daily life? 2) Would you like to wear the second type of lenses in your daily life? 3) Which one do you dislike more? 4) If the lens you dislike can significantly slow myopic progression by 59%, would you like to wear it? (Appendix II; available online at [AJO.com](http://AJO.com)).

- **STATISTICAL ANALYSIS:** Only data from the right eye was used for analysis. The refractive error was expressed as SER, which equals the spherical power plus half the cylindrical power. A paired *t* test was used to compare the difference in VA between the 2 types of lenses under the same circumstance.  $\chi^2$  tests were used to compare the number of complaints of visual symptoms and the acceptance rate be-

tween children and adults. If >20% of cells in the analysis had an expected count <5, the Fisher exact test was applied instead. Wilcoxon signed rank tests were used to compare the severity of visual symptoms between the lenses. Statistical significance was set at  $P < .05$ .

## RESULTS

- **COMPARISON OF VA BETWEEN THE 2 TYPES OF LENSES:** After the spectacles were worn for 30 minutes, there were no statistically significant differences in central distant VA between the 2 types of lenses in either high- or low-contrast VA at standard (Figure 3, Bottom left; both  $P > .05$ ) or dim illuminance (Figure 4, Bottom left; both  $P > .05$ ). However, the VA looking through the mid-peripheral zone was approximately a half line worse with the DIMS lens than with the SV lens, and the affected areas were more prominent in dim illuminance than in standard illuminance (Figure 3, Bottom left, and Figure 4, Bottom left).

In adult volunteers, there were no statistically significant differences in central distant VA between the 2 types of lenses in either high- or low-contrast VA at both levels of illuminance (Figures 3 and 4, Bottom right; all  $P > .05$ ). Nevertheless, mid-peripheral vision was observed to significantly drop down by an extent of  $0.07 \pm 0.09$  to  $0.15 \pm 0.10$  in all 4 quadrants under standard illuminance (Figure 3, Bottom right; all  $P < .05$ ). The reduction of VA was even prominent in dim illuminance (Figure 4, Bottom right).

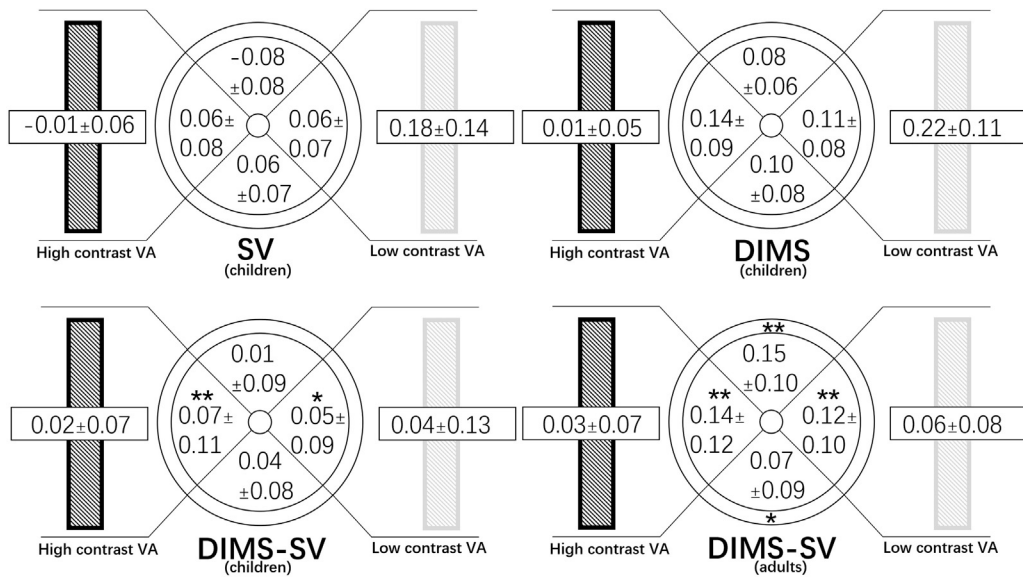

FIGURE 3. Comparison of visual acuity (VA) tested under 500 lux 30 minutes after wearing the single vision (SV) lenses and the Defocus Incorporated Multiple Segments (DIMS) lenses. Three rings in each diagram represent respectively the rim of the central clear vision zone, the mid-peripheral zone, and the outer rim of the lens (inward to outward). The data displayed to the left (deep dark strike bar) and right (light dark strike bar) outside the third ring represent respectively the distant high-contrast (100%) and low-contrast (10%) VA through the central clear vision zone. The data displayed inside the second ring (clockwise, start from left) represent the near VA viewing through the nasal, superior, temporal, and inferior quadrants of the mid-peripheral zone, respectively. (Top left) The VA of children using SV lenses. (Top right) The VA of children using DIMS lenses. (Bottom left) The difference in VA (DIMS – SV) of children. (Bottom right) The difference in VA (DIMS – SV) of adults. All annotations apply for Figures 3 through 6. \* $P < .05$ . \*\* $P < .01$ .

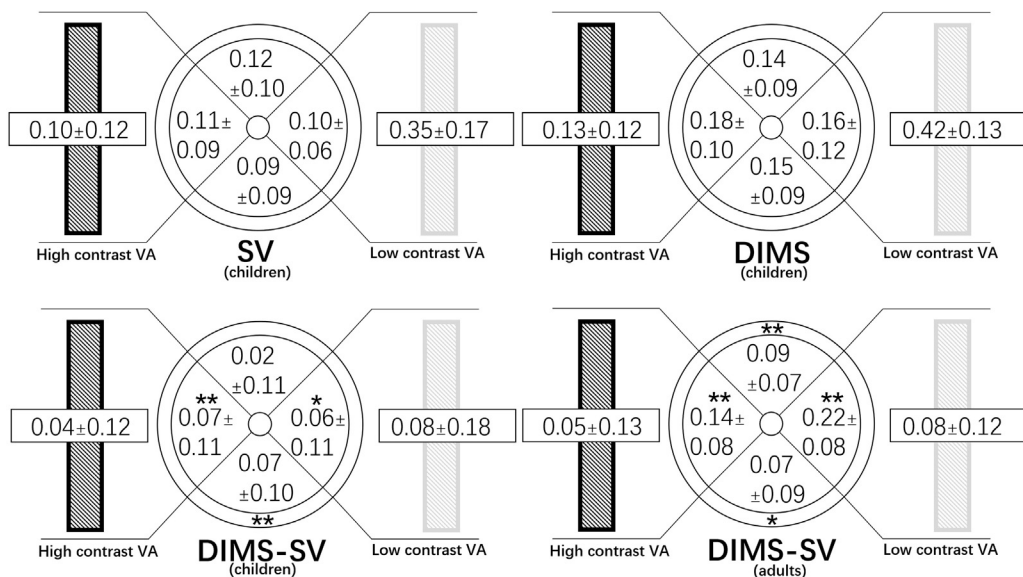

FIGURE 4. Comparison of visual acuity tested under 50 lux 30 minutes after wearing single vision (SV) lenses and the Defocus Incorporated Multiple Segments (DIMS) lenses. Annotations are the same as those in Figure 3.

After the children wore the spectacles for a week, no obvious adaptation was observed. The magnitude and areas of reduced VA through the mid-peripheral zone still

existed in the DIMS lenses (Figures 5 and 6, Bottom left). The same situation occurred for the adult volunteers (Figures 5 and 6, Bottom right).

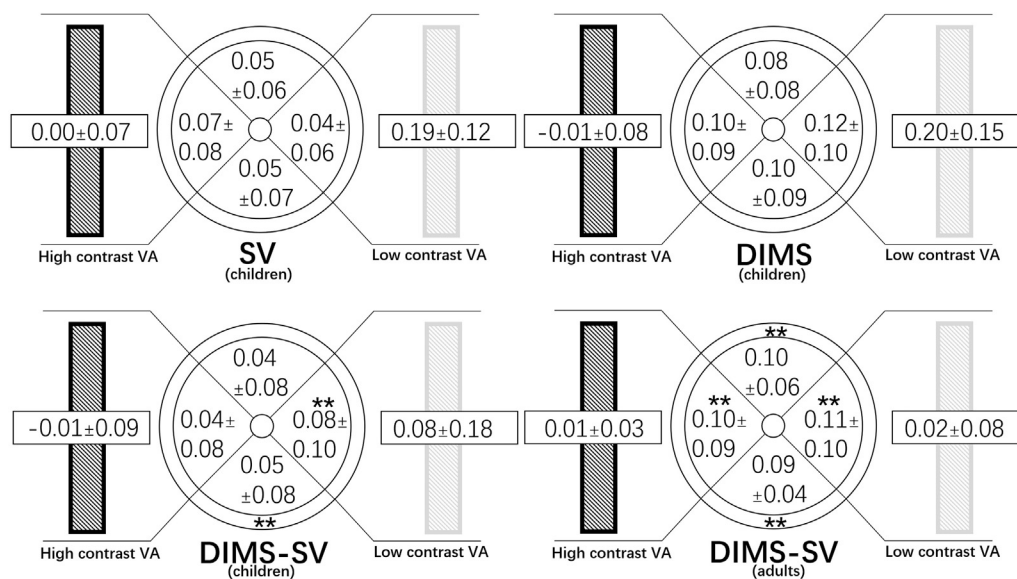

FIGURE 5. Comparison of visual acuity tested under 500 lux 1 week after wearing single vision (SV) lenses and the Defocus Incorporated Multiple Segments (DIMS) lenses. Annotations are the same as those in Figure 3.

• **COMPARISON OF VISUAL SYMPTOMS BETWEEN THE 2 TYPES OF LENSES:** Table 1 shows the number of children with visual symptoms after a week of wearing the DIMS lens or SV lens. There was no significant difference in the number of complaints for all symptoms, except that 7 of 20 children complained about paracentral and peripheral blurry vision for the DIMS lens compared with none for the SV lens ( $P < .01$ ).

In contrast to the children, the adults seemed to be more sensitive to the DIMS lenses. Significantly more complaints about these lenses were reported by adults, including headache, dizziness, paracentral and peripheral blurry vision, and the necessity of adjusting the frame to get clear vision (all  $P < .05$ ).

Tables 2 and 3 show the severity of the visual symptoms scored by children and adults. Similar to the number of complaints, there were no significant differences in the severity of all mentioned visual symptoms reported by the children except that paracentral and peripheral blurry vision happened significantly more often with DIMS lenses than with SV lenses ( $P < .01$ ; Table 2). By contrast, the adults complained about the symptoms of eyestrain, headache, dizziness, nausea, paracentral and peripheral blurry vision, and the necessity of adjusting the frame to get clear vision significantly more severely when wearing the DIMS lenses than when wearing the SV lenses (all  $P < .01$ ; Table 3).

• **ACCEPTANCE OF DIMS LENS:** All children were willing to wear the SV lens in their daily lives, while only 85% (17/20) were willing to wear the DIMS lens. If they were forced to select the lens they disliked, 40% (8/20) of the subjects were unwilling to wear DIMS, but after being

informed that the DIMS lens could slow down the progression of myopia by 59%, then 90% (18/20) of the subjects wanted to wear the DIMS lens.

By comparison, although all adults were willing to wear the SV lens in their daily lives, only 60% (6/10) were willing to wear the DIMS lens. If they had to select 1 of the lenses, 70% (7/10) of the subjects were unwilling to wear the DIMS. This was significantly greater than the proportion of unwillingness children had ( $P = .008$ ; Appendix III, Table 1, available online at AJO.com), indicating that the acceptance rate of the DIMS lens is poorer in adults. Interestingly, when the efficacy of the DIMS lens was discussed, the acceptance proportion increased from 30% (3/10) to 70% (7/10), a similar acceptance rate with children ( $P = .3$ ; Appendix III, Table 2, available online at AJO.com).

## DISCUSSION

THE DIMS LENS WAS A NOVEL DESIGN OF SPECTACLE LENS that exhibited satisfactory efficacy in myopia control in a recent clinical trial. The present study addressed the levels of adaptation and acceptance of the product with Chinese volunteers. No significant difference was found in the central vision between DIMS lenses and traditional SV lenses. Nevertheless, because of the mid-peripheral defocus zone, VA viewing through this zone was diminished by approximately a half line of the Early Treatment Diabetic Retinopathy Study visual chart in children and by 1 line in adults. DIMS lenses were generally well tolerated by children with the occasional but acceptable disturbance of blurred vision

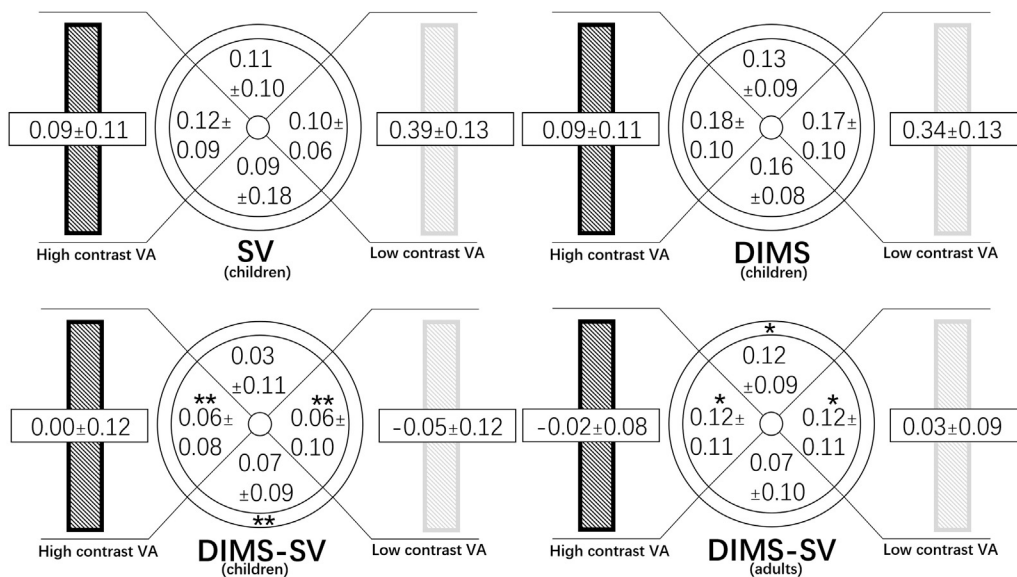

FIGURE 6. Comparison of visual acuity tested under 50 lux 1 week after wearing single vision (SV) lenses and the Defocus Incorporated Multiple Segments (DIMS) lenses. Annotations are the same as those in Figure 3.

TABLE 1. Number of People with Visual Symptoms After Wearing the Defocus Incorporated Multiple Segment or Single Vision Lenses for 1 Week

Symptom, n (%)	Children, n = 20				Adults, n = 10			
	DIMS	SV	Statistics	P Value	DIMS	SV	Statistics	P Value
Eyestrain	7 (35)	9 (45)	0.419 <sup>a</sup>	.519	6 (60)	1 (10)	— <sup>b</sup>	.057
Headache	4 (20)	3 (15)	— <sup>b</sup>	1.000	5 (50)	0 (0)	— <sup>b</sup>	.033 <sup>c</sup>
Dizziness	5 (25)	3 (15)	— <sup>b</sup>	.695	8 (80)	1 (10)	— <sup>b</sup>	.002 <sup>c</sup>
Diplopia	2 (10)	1 (5)	— <sup>b</sup>	1.000	5 (50)	1 (10)	— <sup>b</sup>	.141
Nausea	1 (5)	1 (5)	— <sup>b</sup>	1.000	4 (40)	0 (0)	— <sup>b</sup>	.087
Photophobia	0 (0)	2 (10)	— <sup>b</sup>	1.000	2 (20)	1 (10)	— <sup>b</sup>	1.000
PPBV	7 (35)	0 (0)	— <sup>b</sup>	.008 <sup>c</sup>	10 (100)	1 (10)	— <sup>b</sup>	<.001 <sup>c</sup>
AFCV	9 (45)	4 (20)	2.849 <sup>a</sup>	.091	9 (90)	1 (10)	12.800 <sup>a</sup>	<.001 <sup>c</sup>
Darkened vision field	1 (5)	1 (5)	— <sup>b</sup>	1.000	1 (10)	0 (0)	— <sup>b</sup>	1.000
Color change	0 (0)	0 (0)	— <sup>b</sup>	1.000	1 (10)	0 (0)	— <sup>b</sup>	1.000
Ghosting images	4 (20)	1 (5)	— <sup>b</sup>	.342	3 (30)	1 (10)	— <sup>b</sup>	.582
Metamorphopsia	0 (0)	1 (5)	— <sup>b</sup>	1.000	1 (10)	0 (0)	— <sup>b</sup>	1.000

AFCV = adjust the frame to get clear vision; DIMS = Defocus Incorporated Multiple Segment; PPBV = paracentral and peripheral blurry vision; SV = single vision.

<sup>a</sup>Pearson  $\chi^2$  test.

<sup>b</sup>Fisher exact test.

<sup>c</sup>Differences between DIMS and SV were statistically significant ( $P < .01$ ).

in the mid-peripheral direction. By contrast, adults seemed to be less tolerant of this novel design.

There have been a range of interventions tested in clinics for myopia control. These interventions can be categorized into 3 classes: spectacle lenses, contact lenses, and pharmacologic medication. In a recent meta-analysis, Huang and associates<sup>28</sup> summarized the fact that the

most effective interventions were pharmacologic—for example, atropine—followed by specially designed contact lenses, including orthokeratology and peripheral defocus modifying contact lenses, and then followed by specially designed spectacle lenses. However, considering the topical and systematic side effects, long-term safety, tolerance, and convenience to implement, children and their

**TABLE 2.** Severity of Visual Symptoms Scored by Wearing the Defocus Incorporated Multiple Segment or Single Vision Lenses in 1 Week in Children

	DIMS	SV	Z	P Value
<b>Eye strain</b>				
0	15 (65)	11 (55)	-1.383 <sup>a</sup>	.167
1	5 (35)	8 (40)	—	—
2	0 (0)	1 (5)	—	—
<b>Headache</b>				
0	16 (80)	17 (85)	-0.411 <sup>a</sup>	.681
1	4 (20)	3 (15)	—	—
<b>Dizziness</b>				
0	15 (65)	17 (85)	-0.781 <sup>a</sup>	.435
1	5 (35)	3 (15)	—	—
<b>Diplopia</b>				
0	18 (90)	19 (95)	-0.593 <sup>a</sup>	.553
1	2 (10)	1 (5)	—	—
<b>Nausea</b>				
0	19 (95)	19 (95)	0 <sup>a</sup>	1.000
1	1 (5)	1 (5)	—	—
<b>Photophobia</b>				
0	19 (95)	18 (90)	-0.593 <sup>a</sup>	.553
1	1 (5)	2 (10)	—	—
<b>Paracentral and peripheral blurry vision</b>				
0	13 (65)	20 (100)	-2.870 <sup>a</sup>	.004 <sup>b</sup>
1	6 (30)	0 (0)	—	—
2	1 (5)	0 (0)	—	—
<b>Adjust the frame to get clear vision</b>				
0	11 (55)	16 (80)	-1.782 <sup>a</sup>	.075
1	7 (35)	4 (20)	—	—
2	2 (10)	0 (0)	—	—
<b>Darkened vision field</b>				
0	19 (95)	19 (95)	-0.036 <sup>a</sup>	.971
1	1 (5)	0 (0)	—	—
2	0 (0)	1 (5)	—	—
<b>Color change</b>				
0	20 (100)	20 (100)	0 <sup>a</sup>	1.000
<b>Ghosting images</b>				
0	16 (80)	19 (95)	-1.416 <sup>a</sup>	.157
1	4 (20)	1 (5)	—	—
<b>Metamorphopsia</b>				
0	20 (100)	19 (95)	-1.000 <sup>a</sup>	.317
1	0 (0)	1 (5)	—	—

DIMS = Defocus Incorporated Multiple Segment; SV = single vision.

Score was given according to the frequency of occurrence: 0 = none (0 times/day), 1 = occasionally (1-2 times/day), 2 = sometimes (3-4 times/day), 3 = always (5-6 times/day), 4 = complete (>7 times/day).

<sup>a</sup>Wilcoxon signed rank test.

<sup>b</sup>Differences between DIMS and SV were statistically significant ( $P < .01$ ).

parents are likely to select these interventions in the opposite order. That is, spectacle lenses, which have been widely used for centuries, would be the first option for parents to choose for myopia control if they could provide similar (or even relatively less) efficacy. In this sense, the DIMS lens, based on the preliminary results from a recent clinical trial,<sup>18,19</sup> would likely be the first line of intervention for myopia control in the future.

The basic rationale of DIMS design is to exert myopic defocus in the mid-peripheral retina while maintaining the central retina in focus. The retina has been found to be able to discern and integrate simultaneous defocus with different signs.<sup>29–32</sup> Central refractive development was modulated by not only the sign and dioptric magnitude of the optical defocus but also by the location of the retina where defocus was imposed, with the

**TABLE 3.** The Severity of Visual Symptoms Scored by Wearing the Defocus Incorporated Multiple Segment or Single Vision Lenses in 1 Week in Adults

	DIMS	SV	Z	P Value
<b>Eyestrain</b>				
0	4 (40)	9 (90)	-2.447 <sup>a</sup>	.014 <sup>c</sup>
1	1 (10)	1 (10)	—	—
2	3 (30)	0 (0)	—	—
3	2 (20)	0 (0)	—	—
<b>Headache</b>				
0	5 (50)	10 (100)	-2.490 <sup>a</sup>	.013 <sup>c</sup>
1	3 (30)	0 (0)	—	—
2	1 (10)	0 (0)	—	—
3	1 (10)	0 (0)	—	—
<b>Dizziness</b>				
0	2 (20)	9 (90)	-2.734 <sup>a</sup>	.006 <sup>b</sup>
1	6 (60)	0 (0)	—	—
2	1 (10)	1 (10)	—	—
3	1 (10)	0 (0)	—	—
<b>Diplopia</b>				
0	5 (50)	9 (90)	-1.970 <sup>a</sup>	.049
1	3 (30)	1 (10)	—	—
2	2 (20)	0 (0)	—	—
<b>Nausea</b>				
0	6 (60)	10 (100)	-2.179 <sup>a</sup>	.029 <sup>c</sup>
1	4 (40)	0 (0)	—	—
<b>Photophobia</b>				
0	8 (80)	9 (90)	-0.730 <sup>a</sup>	.465
1	0 (0)	1 (10)	—	—
2	2 (20)	0 (0)	—	—
<b>Paracentral and peripheral blurry vision</b>				
0	0 (0)	9 (90)	-3.869 <sup>a</sup>	<.001 <sup>b</sup>
1	4 (40)	1 (10)	—	—
2	5 (50)	0 (0)	—	—
4	1 (10)	0 (0)	—	—
<b>Adjust the frame to get clear vision</b>				
0	1 (10)	9 (90)	-3.612 <sup>a</sup>	<.001 <sup>b</sup>
1	1 (10)	1 (10)	—	—
2	2 (20)	0 (0)	—	—
3	6 (60)	0 (0)	—	—
<b>Darkened vision field</b>				
0	9 (90)	10 (100)	-1.000 <sup>a</sup>	.317
1	1 (10)	0 (0)	—	—
2	0 (0)	0 (0)	—	—
<b>Color change</b>				
0	9 (90)	10 (100)	-1.000 <sup>a</sup>	.317
1	1 (10)	0 (0)	—	—
<b>Ghosting images</b>				
0	7 (70)	9 (90)	-1.139 <sup>a</sup>	.255
1	2 (20)	1 (10)	—	—
2	1 (10)	0 (0)	—	—
<b>Metamorphopsia</b>				
1	9 (90)	10 (100)	-1.000 <sup>a</sup>	.317
2	1 (10)	0 (0)	—	—

DIMS = Defocus Incorporated Multiple Segment; SV = single vision.

Score was given according to the frequency of occurrence: 0 = none (0 times/day), 1 = occasionally (1-2 times/day), 2 = sometimes (3-4 times/day), 3 = always (5-6 times/day), 4 = complete (>7 times/day).

<sup>a</sup>Wilcoxon signed rank test.

<sup>b</sup>Differences between DIMS and SV were statistically significant ( $P < .01$ ,  $P < .05$ ).



superior retina most responsive to the imposed defocus (reviewed by Smith<sup>33</sup>). In addition, central refractive development was affected by the area ratio imposed on the retina of defocus cues, although the magnitude of response varied among different species. For example, Tse and associates<sup>30</sup> observed that in chicks, with a 50:50 ratio of defocus area in the lens, a dual-power lens of +10 D/−10 D resulted in a hyperopic refractive shift, and a −10 D hyperopic defocus could be overwhelmed already by +5 D of myopic defocus. Animal studies have indicated that a stimulus produced by myopic defocus is generally more potent than that produced by a hyperopic one.<sup>30,34,35</sup> Several optical methods based on this notion have also been validated, albeit with different levels of magnitude, for myopia control in children.<sup>16–18,20</sup> This indicates that exerting a myopic defocus in the retina is a robust strategy by which to limit myopia progression.

To shift the image artificially out of focus would definitely cause the reduction of VA and lead to related visual discomfort. Therefore, the key concern of interventions applying the peripheral defocus modifying concept is to balance the clinical efficacy and the scarification of the related visual quality. Unsurprisingly, there was approximately a half-line EDTRS drop of VA in the mid-peripheral direction observed for the DIMS lens, which is slightly less when compared with other interventions of this kind.<sup>18</sup> This is attributed to the honeycomb design of the DIMS lens, in which the myopic defocus area is distributed in a uniform manner with a clear vision area with a 50:50 area ratio. Also, given the large diameter of the central clear zone (9.4 mm), the VA of the primary gaze was well preserved. As a result, the DIMS was given positive tolerance and acceptance by the children in the current study. By contrast, it was less favored by adult subjects. This might be because adults tend to have smaller pupils than children<sup>36–38</sup> and therefore less central clear area were overlapped when adults move their eyeball off the primary gaze. However, it could also be that our adult subjects were all resident ophthalmologists. Their responses might be somewhat oversensitive compared with those of average adults. In any case, the fact that 70% of these adult subjects were willing to wear the DIMS lens for myopia control indicates that the current design has

achieved a good balance between the clinical efficacy and the influence of visual quality.

A possible limitation of this study is the relatively small sample size. However, power calculation showed that a sample size of 20 children produced a power >80% for the mid-periphery VA, the primary outcome of this study, in the majority of circumstances, including both standard and dim ambient illuminance, both at the 30-minute and 1-week visit times. Meanwhile, it showed that this sample size was unable to provide sufficient power (as low as 0.7% for the comparison of high contrast VA under standard illuminance in the 1-week visit) to test the possible difference in the central VA between the 2 types of lenses. Given the large central clear zone of the DIMS lens, it is reasonable to expect a low likelihood to detect a significant difference between the 2 types of the lenses. Therefore, this parameter had been regarded as the secondary outcome before the start of the study. However, it is acknowledged that an enrollment of more subjects could have provided more information as to other concerns of interest, such as whether the level of acceptance of DIMS lenses depends on the level of refractive error or anisometropia. Continued investigation is therefore warranted to help better guide the use of DIMS lenses in practice. In addition, although preliminary results showed that DIMS lenses produced significant retardation of myopia progression and that they were well tolerated by children, 2 important questions remain. First, is +3.50 D the amount of defocus that achieves the maximum antimyopia effect? Second, is 50:50 the area ratio that achieves the maximum antimyopia effect? The optimal defocus amount and area ratio for human myopia control require additional study.

In summary, for children in China, after wearing DIMS lenses, central vision is no different from that with traditional SV lenses, but the mid-peripheral defocus area has a certain impact on vision (the children dropped by 3 optotypes on average, or 0.06 logarithm of minimal angle of resolution unit), which cannot be adapted within a week. Blurred mid-peripheral vision is the main visual symptom, but the noticeable occurrence is not frequent (once or twice a day). In general, Chinese children, informed of the average retardation rate of myopia progression, prefer the DIMS lens (90%), given the option.

---

ALL AUTHORS HAVE COMPLETED AND SUBMITTED THE ICMJE FORM FOR DISCLOSURE OF POTENTIAL CONFLICTS OF INTEREST. The project was supported by Hunan Provincial Science and Technology Plan Project (2019SK2051). Publication of this work was supported by Hoya Co., Ltd. Dr Lan received a grant from The Science Fund for Distinguished Young Scientists Scientists (2019JJ20034) from the Hunan Provincial Science and Technology Department, China. Financial Disclosures: The authors indicate no financial conflict of interest. All authors attest that they meet the current ICMJE criteria for authorship.

---

## REFERENCES

1. Holden BA, Fricke TR, Wilson DA, et al. Global prevalence of myopia and high myopia and temporal trends from 2000 through 2050. *Ophthalmology* 2016;123(5):1036–1042.
2. Ding BY, Shih YF, Lin LL, Hsiao CK, Wang IJ. Myopia among schoolchildren in East Asia and Singapore. *Surv Ophthalmol* 2017;62(5):677–697.
3. Shen L, Melles RB, Metlapally R, et al. The association of refractive error with glaucoma in a multiethnic population. *Ophthalmology* 2016;123(1):92–101.

4. Grødum K, Heijl A, Bo B. Refractive error and glaucoma. *Acta Ophthalmol Scand* 2001;79(6):560–566.
5. Wong YL, Saw SM. Epidemiology of pathologic myopia in Asia and worldwide. *Asia Pac J Ophthalmol (Phila)* 2016; 5(6):394–402.
6. Saw SM, Gazzard G, Shih-Yen EC, Chua WH. Myopia and associated pathological complications. *Ophthalmic Physiol Opt* 2005;25(5):381–391.
7. Schaeffel F, Glasser A, Howland HC. Accommodation, refractive error and eye growth in chickens. *Vision Res* 1988; 28(5):639–657.
8. Wallman J, Winawer J. Homeostasis of eye growth and the question of myopia. *Neuron* 2004;43(4):447–468.
9. Benavente-Perez A, Nour A, Troilo D. Axial eye growth and refractive error development can be modified by exposing the peripheral retina to relative myopic or hyperopic defocus. *Invest Ophthalmol Vis Sci* 2014;55(10):6765–6773.
10. Benavente-Perez A, Nour A, Troilo D. The effect of simultaneous negative and positive defocus on eye growth and development of refractive state in marmosets. *Invest Ophthalmol Vis Sci* 2012;53(10):6479–6487.
11. McBrien NA, Arumugam B, Metlapally S. The effect of daily transient +4 D positive lens wear on the inhibition of myopia in the tree shrew. *Invest Ophthalmol Vis Sci* 2012;53(3): 1593–1601.
12. Arumugam B, Hung LF, To CH, Holden B, Smith EL 3rd. The effects of simultaneous dual focus lenses on refractive development in infant monkeys. *Invest Ophthalmol Vis Sci* 2014;55(11):7423–7432.
13. Metlapally S, McBrien NA. The effect of positive lens defocus on ocular growth and emmetropization in the tree shrew. *J Vis* 2008;8(3):1. 1–12.
14. Smith EL 3rd, Hung LF, Huang J, Blasdel TL, Humbird TL, Bockhorst KH. Effects of optical defocus on refractive development in monkeys: evidence for local, regionally selective mechanisms. *Invest Ophthalmol Vis Sci* 2010;51(8): 3864–3873.
15. Tepelus TC, Vazquez D, Seidemann A, Uttenweiler D, Schaeffel F. Effects of lenses with different power profiles on eye shape in chickens. *Vision Res* 2012;54:12–19.
16. Lam CSY, Tang WC, Tse YY, Ying YT, Chi HT. Defocus Incorporated Soft Contact (DISC) lens slows myopia progression in Hong Kong Chinese schoolchildren: a 2-year randomised clinical trial. *Br J Ophthalmol* 2014;98(1):40–45.
17. Anstice NS, Phillips JR. Effect of dual-focus soft contact lens wear on axial myopia progression in children. *Ophthalmology* 2011;118(6):1152–1161.
18. Sankaridurg P, Donovan L, Varnas S, et al. Spectacle lenses designed to reduce progression of myopia: 12-month results. *Optom Vis Sci* 2010;87(9):631–641.
19. Lam CSY, Tang WC, Tse DY, et al. Defocus Incorporated Multiple Segments (DIMS) spectacle lenses slow myopia progression: a 2-year randomised clinical trial. *Br J Ophthalmol* <https://doi.org/10.1136/bjophthalmol-2018-313739>.
20. Sankaridurg P, Holden B, Smith E 3rd, et al. Decrease in rate of myopia progression with a contact lens designed to reduce relative peripheral hyperopia: one-year results. *Invest Ophthalmol Vis Sci* 2011;52(13):9362–9367.
21. Edwards MH, Li RW, Lam CS, Lew JK, Yu BS. The Hong Kong progressive lens myopia control study: study design and main findings. *Invest Ophthalmol Vis Sci* 2002;43(9): 2852–2858.
22. Gwiazda J, Hyman L, Hussein M, et al. A randomized clinical trial of progressive addition lenses versus single vision lenses on the progression of myopia in children. *Invest Ophthalmol Vis Sci* 2003;44(4):1492–1500.
23. Hasebe S, Ohtsuki H, Nonaka T, et al. Effect of progressive addition lenses on myopia progression in Japanese children: a prospective, randomized, double-masked, crossover trial. *Invest Ophthalmol Vis Sci* 2008;49(7):2781–2789.
24. Yang Z, Lan W, Ge J, et al. The effectiveness of progressive addition lenses on the progression of myopia in Chinese children. *Ophthalmic Physiol Opt* 2009;29(1):41–48.
25. Correction of Myopia Evaluation Trial 2 Study Group for the Pediatric Eye Disease Investigator Group. Progressive-addition lenses versus single-vision lenses for slowing progression of myopia in children with high accommodative lag and near esophoria. *Invest Ophthalmol Vis Sci* 2011;52(5):2749–2757.
26. Berntsen DA, Sinnott LT, Mutti DO, Zadnik K. A randomized trial using progressive addition lenses to evaluate theories of myopia progression in children with a high lag of accommodation. *Invest Ophthalmol Vis Sci* 2012;53(2):640–649.
27. Park GE, Park RS. Further evidence of change in position of the eyeball during fixation. *Arch Ophthalmol* 1940;23(6): 1216–1230.
28. Huang J, Wen D, Wang Q, et al. Efficacy comparison of 16 interventions for myopia control in children: a network meta-analysis. *Ophthalmology* 2016;123(4):697–708.
29. Mcfadden SA, Tse DY, Bowrey HE, et al. Integration of defocus by dual power Fresnel lenses inhibits myopia in the mammalian eye. *Invest Ophthalmol Vis Sci* 2014;55(2):908–917.
30. Tse DY, Lam CS, Guggenheim JA, et al. Simultaneous defocus integration during refractive development. *Invest Ophthalmol Vis Sci* 2007;48(12):5352–5359.
31. Smith EL, Hung LF. The role of optical defocus in regulating refractive development in infant monkeys. *Vision Res* 1999; 39(8):1415–1435.
32. Smith EL, Hung LF, Huang J, Arumugam B. Effects of local myopic defocus on refractive development in monkeys. *Optom Vis Sci* 2013;90(11):1176–1186.
33. Smith EL. Optical treatment strategies to slow myopia progression: effects of the visual extent of the optical treatment zone. *Exp Eye Res* 2013;114:77–88.
34. Schmid KL, Wildsoet CF. Effects on the compensatory responses to positive and negative lenses of intermittent lens wear and ciliary nerve section in chicks. *Vision Res* 1996; 36(7):1023–1036.
35. Winawer J, Zhu X, Choi J, Wallman J. Ocular compensation for alternating myopic and hyperopic defocus. *Vision Res* 2005;45(13):1667–1677.
36. Winn B, Whitaker D, Elliott DB, Phillips NJ. Factors affecting light-adapted pupil size in normal human subjects. *Invest Ophthalmol Vis Sci* 1994;35(3):1132–1137.
37. Nakamura K, Bissen-Miyajima H, Oki S, Onuma K. Pupil sizes in different Japanese age groups and the implications for intra-ocular lens choice. *J Cataract Refract Surg* 2009;35(1):134–138.
38. Guillon M, Dumbleton K, Theodoratos P, Gobbe M, Wooley CB, Moody K. The effects of age, refractive status, and luminance on pupil size. *Optom Vis Sci* 2016;93(9): 1093–1100.